

Dated 2019

## **Planning Agreement**

### **Reservoir Protection Mechanism (subdivided)**

Parties

**Melbourne Water Corporation (Melbourne Water)**  
ABN 81 945 386 953

**Peet Craigieburn Pty Limited (as Owner and Developer)**  
ACN 100 290 640

Sally Macindoe  
Norton Rose Fulbright Australia  
RACV Tower, 485 Bourke Street  
Melbourne VIC 3000  
Tel: +61 (0)3 8686 6000  
nortonrosefulbright.com  
Our ref: 2841164

## Contents

1	Definitions and interpretation.....	4
2	Obligations run with the Land.....	7
3	Owner’s acknowledgments.....	7
4	Specific Obligations of the Owner .....	7
5	Obligations of the Developer .....	9
6	Powers of Melbourne Water and Developer .....	11
7	Earlier Agreement.....	11
8	Further Obligations of the Owner .....	11
9	Indemnities .....	12
10	Further assurance .....	13
11	Agreement under section 173 of the Act.....	13
12	Owner’s warranties.....	13
13	Planning objectives.....	13
14	Successors in title.....	13
15	Goods and Service Tax.....	13
16	General Matters .....	14
17	Commencement of Agreement.....	15
18	Amendment .....	15
19	Ending of Agreement.....	16
20	Counterparts .....	16
	Mortgagee’s consent.....	18
	Appendix 1 – Location Plan – Backslope and Fencing.....	19
	Appendix 2 – Building Zones Plan .....	23
	Appendix 3 – Landscaping Schedule.....	29
	Appendix 4 – Engineered Footing Zone Specifications .....	35
	Appendix 5 – Permanent Reservoir Protection Plan.....	40

**Deed** dated \_\_\_\_\_ under section 173 of the *Planning and Environment Act 1987 (Act)*

**Parties:** **Melbourne Water Corporation**  
of 990 Latrobe Street, Docklands, Victoria  
**(Melbourne Water)**

**Peet Craigieburn Pty Limited**  
of Level 7, 200 St Georges Terrace, Perth, Western Australia  
**(Owner)**

**Peet Craigieburn Pty Limited**  
of Level 7, 200 St Georges Terrace, Perth, Western Australia  
**(Developer)**

## Introduction

- A** Melbourne Water is responsible for the management of the Greenvale Reservoir and for management of drainage of the Land under the *Water Act 1989*.
- B** The Owner is the registered proprietor or entitled to be registered as the proprietor of an estate in fee simple of the Land.
- C** The Developer is the developer of the Land.
- D** The Land is subject to registered mortgage no. AH739084N in favour of the Mortgagee. The Mortgagee has consented to the Owner entering into this Agreement.
- E** The Land is located within the catchment of the Greenvale Reservoir, and is affected by the Environmental Significance Overlay, Schedule 9.
- F** On 7 August 2018, Hume City Council issued the Planning Permit. Among other things, the Planning Permit authorised the subdivision of the Land.
- G** The Developer has constructed the Protection Mechanism on the Land pursuant to the Earlier Permit.
- H** The following conditions were included in the Planning Permit at Melbourne Water's request:
56. *No subdivisional stage works must be constructed or carried out within the portion of the Precinct that falls within the natural catchment of the Greenvale Reservoir until the required 1 in 1 million year Reservoir Interim Protection works proposed on this site have been completed to Melbourne Water's satisfaction.*
57. *The required 1 in 1 million year Reservoir Protection works and interim solution servicing the Precinct are to be designed and constructed to Melbourne Water's requirements*
- ....
61. *Prior to the issue of a statement of compliance, the landowner must enter in to a Section 173 Agreement with Melbourne Water. All costs associated with the creation of the agreement must be borne by the permit holder.*

*The agreement must be registered on title and run with the land, and must, to the satisfaction of Melbourne Water, require works to be maintained by the landowner and future lot owners for lot land shaping, to form an interim protection mechanism for the Greenvale Reservoir (4360/09) to provide protection from stormwater flows up to and including the 1 in 1,000,000 year ARI event.*

- I** Melbourne Water requires this Agreement in order to secure compliance with the public works requirements of the Planning Permit as a condition of consent to issue of a statement of compliance under section 21 of the *Subdivision Act 1988*.
- J** Melbourne Water enters into this Agreement pursuant to section 17(2)(c) and 17(3) of the *Subdivision Act 1988*.
- K** The parties enter into this Agreement in order to:
- (1) satisfy conditions of the Planning Permit and the Earlier Permit;
  - (2) satisfy the requirements of Environmental Significance Overlay, Schedule 9;
  - (3) ensure that protective measures are implemented to prevent urban stormwater, or other water or effluent, entering the Greenvale Reservoir from or across the Land; and
  - (4) achieve or advance the objectives of planning in Victoria and the objectives of the Scheme in relation to the Land.

## **It is agreed**

### **1 Definitions and interpretation**

#### **1.1 Definitions**

In this Agreement:

- (1) **Act** means the *Planning and Environment Act 1987* (Vic);
- (2) **Agreement** means this document and any agreement executed by the parties expressed to be supplemental to this document;
- (3) **Backslope** means the part of the Protection Mechanism that slopes towards the Greenvale Reservoir shown as 'Backslope' on the Location Plan and the Building Envelope Plan;
- (4) **Building Zones Plan** means the plan included at Appendix 2;
- (5) **Building Envelope Zone 1** means the area identified as such in the Building Envelope Plan;
- (6) **Building Envelope Zone 2** means the area identified as such in the Building Envelope Plan;
- (7) **Developer** means Peet Craigieburn Pty Limited, ACN 100 290 640 and includes its agents, officers, employees, servants, workers and contractors;
- (8) **Earlier Agreement** means the agreement between the parties under section 173 of the Act with dealing number AR282423Y;

- (9) **Earlier Permit** means planning permit number P18800, issued on 1 July 2016, for staged multi-lot subdivision, construction of dwellings on lots less than 300m<sup>2</sup> and the construction of an interim bund in accordance with the endorsed plans, and includes any plans endorsed under it, as amended from time to time;
- (10) **Engineered Footing Zone Specifications** means the specifications included at Appendix 4;
- (11) **Exclusion Zone** means the area identified as such in the Building Envelope Plan;
- (12) **Fencing** means a Colorbond fence of 1.8 metres in height and coloured Grey Ridge or equivalent;
- (13) **Greenvale Reservoir** means the reservoir located approximately 21 kilometres north-north-west of Melbourne which stores potable water and which is owned and managed by Melbourne Water;
- (14) **GST Act** means the *A New Tax System (Goods and Services Tax) Act 1999* (Cth) (as amended) from time to time;
- (15) **Land** means:
- (a) the land contained in Volume 11976 Folio 746, being Lot A on PS 742770J;
  - (b) the land contained in Volume 11985 Folio 405, being Lot B on PS801126M;
  - (c) the land contained in Volume 12030 Folio 219, being Lot C on PS807644F; and
  - (d) the land contained in Volume 12041 Folio 272, being Lot D on PS810905K;
- and includes any lot created by the subdivision of the Land or any part of it;
- (16) **Landscaping Schedule** means a schedule of landscaping works required to be carried out on the Backslope, including a landscaping setout plan, as approved by Melbourne Water from time to time. A copy of the schedule as at the date of this Agreement is included in Appendix 2;
- (17) **Location Plan** means the plan contained at Appendix 1;
- (18) **Melbourne Water** means Melbourne Water Corporation (ABN 81 945 386 953) and includes its agents, officers, employees, servants, workers and contractors;
- (19) **Mortgagee** means ANZ Fiduciary Services Pty Ltd, being the person registered or entitled to be registered as the mortgagee of the Land or any part of it;
- (20) **Occupier** includes a person who is in occupation or control of the Land whether or not that person is the owner of the Land and in relation to land different parts of which are occupied by different persons means the respective persons in occupation or control of each part;
- (21) **Owner** means the person or persons registered or entitled to be registered by the Registrar of Titles as proprietor or proprietors of an estate in fee simple of the Land or any part of it and includes a mortgagee in possession;
- (22) **Permanent Reservoir Protection Plan** means the plan contained at Appendix 5;

- (23) **Planning Permit** means the Planning Permit number 19872, issued on 5 July 2018 and amended on 7 August 2018, for a staged, multi-lot subdivision and the creation of easements and restrictions in accordance with the endorsed plans, and includes any plans endorsed under it, as amended from time to time;
- (24) **Planning Scheme** means the Hume Planning Scheme and any successor instrument or other planning scheme which applies to the Land;
- (25) **Protection Mechanism** means a combination of earth shaping, retaining walls and/or other measures to a level necessary to protect the Greenvale Reservoir from overland stormwater flows in the projected 1 in 1 million year flood event, located on the Land, as constructed to Melbourne Water's satisfaction in accordance with condition 64 of the Earlier Permit;
- (26) **Rectification Notice** means a notice that:
  - (a) specifies actions required to remedy a breach of this Agreement and the timeframe or timeframes within which rectification must occur; and
  - (b) may specify both interim or temporary and ultimate works or actions.
- (27) **Tribunal** means the Victorian Civil and Administrative Tribunal or its successor; and
- (28) **Works** has the meaning specified in the Act.

## 1.2 Interpretation

- (1) Reference to:
  - (a) one gender includes the others;
  - (b) the singular includes the plural and the plural includes the singular;
  - (c) a person includes a body corporate;
  - (d) a party includes the party's executors, administrators, successors and permitted assigns;
  - (e) a thing includes the whole and each part of it separately;
  - (f) a statute, regulation, code or other law or a provision of any of them includes:
    - (i) any amendment or replacement of it; and
    - (ii) another regulation or other statutory instrument made under it, or made under it as amended or replaced; and
  - (g) dollars means Australian dollars unless otherwise stated.
- (2) "Including" and similar expressions are not words of limitation.
- (3) Where a word or expression is given a particular meaning, other parts of speech and grammatical forms of that word or expression have a corresponding meaning.
- (4) Headings and any table of contents or index are for convenience only and do not form part of this Agreement or affect its interpretation.

- (5) A provision of this Agreement must not be construed to the disadvantage of a party merely because that party was responsible for the preparation of the Agreement or the inclusion of the provision in the Agreement.
- (6) If an act must be done on a specified day which is not a Business Day, it must be done instead on the next Business Day.
- (7) This Agreement does not in any way limit the application of the Act.

### 1.3 Parties

- (1) If a party consists of more than 1 person, this Agreement binds each of them separately and any 2 or more of them jointly.
- (2) An obligation, representation or warranty in favour of more than 1 person is for the benefit of them separately and jointly.
- (3) A party which is a trustee is bound both personally and in its capacity as a trustee.

## 2 Obligations run with the Land

The obligations of the Owner under this Agreement, take effect as separate and several covenants which are annexed to and run at law and equity with the Land. If the Land is subdivided, this Agreement must be read and applied so that each subsequent Owner of a lot is only responsible for those covenants and obligations which relate to that Owner's lot.

## 3 Owner's acknowledgments

The Owner acknowledges:

- (1) the requirement for the Protection Mechanism and the function of the Protection Mechanism of protecting the Greenvale Reservoir from stormwater flows; and
- (2) the obligations imposed by this Agreement in relation to the use and development of the Land.

## 4 Specific Obligations of the Owner

### 4.1 Use and development of Land (excluding the Backslope and Exclusion Zone)

In relation to the Land (excluding the parts of the Land referred to in clauses 4.3 and 4.4), the Owner must not:

- (a) undertake any excavation, except that which is necessary for the purpose of constructing a residential slab or an associated above ground shed/outbuilding and ancillary works including foundations, footings, services and landscaping of any front garden;

Example: construction of a basement room, in-ground swimming pool, sunken rear garden or in-ground trampoline is prohibited.

- (b) develop any Land that is outside of the Building Envelope Zone 1 or Building Envelope Zone 2; or
- (c) use or undertake any buildings or works on the Land for any non-residential purpose.

#### 4.2 Use and development of Land within the Building Envelope Zone 2

In relation to Land within the Building Envelope Zone 2, the Owner must not:

- (a) undertake any buildings or works unless those buildings and works comply with the Engineered Footing Zone Specifications;
- (b) store more than 400 litres of liquid on the Land; or
- (c) plant or maintain any trees or shrubs on the Land that can grow taller than 5 metres at full maturity.

#### 4.3 Use and development of Land within the Exclusion Zone

In relation to Land within the Exclusion Zone, the Owner must not:

- (a) undertake any buildings and works that involve excavation (excluding planting or maintaining any trees or shrubs on the Land that do not exceed 5 metres at full maturity);
- (b) store more than 400 litres of liquid on the Land; or
- (c) plant or maintain any trees or shrubs on the Land that can grow taller than 5 metres at full maturity.

#### 4.4 Use and development of Land within the Backslope

In relation to Land located within the Backslope, the Owner must not:

- (a) undertake any buildings and works or excavation; or
- (b) store any substances that could, if released into the environment, affect the water quality of the Greenvale Reservoir.

Examples: fuel, oil, pesticides, herbicides, cleaning products, pool chemicals, construction materials and personal care products.
--

#### 4.5 Fencing

The Owner must:

- (1) maintain the Fencing installed under clause 5.1 in good order and repair; and
- (2) not remove or interfere with or do anything on a lot which would damage or impede the Fencing installed under clause 5.1.

#### 4.6 Landscaping

The Owner agrees not to remove or interfere with or do anything on a lot which would damage or impede the landscaping established on the Backslope.

#### 4.7 Notification to others

- (1) The Owner must:
  - (a) notify any Occupier of the existence of the Agreement by providing a copy of this Agreement;



- (b) require any Occupier to comply with the obligations of the Owner during its occupation; and
- (c) notify any person carrying out works on Land that would or may affect the Protection Mechanism of the existence of the Agreement, and require the person to comply with the obligations of the Owner during works.

Example: works that would or may change the height of the Protection Mechanism directly, by removing soil from the top, or indirectly, by creating a risk of subsidence

- (2) The Owner acknowledges that its obligations under this Agreement are not discharged by carrying out notification in accordance with this clause and that the Owner remains liable for any failure of an Occupier to comply with any relevant obligations under this Agreement.
- (3) Subject to clause 4.7(2), the Developer and Melbourne Water are not liable for any failure of any subsequent Owner to comply with 4.7(1) in relation to the re-sale of a residential lot.

#### 4.8 **Rectification Notice**

- (1) Where the Developer or Melbourne Water reasonably believes that there has been a failure by an Owner to comply with this Agreement, Melbourne Water may issue a Rectification Notice to an Owner.
- (2) Except where rectification is, in the opinion of the Developer or Melbourne Water, required urgently, the Developer or Melbourne Water should consult with the Owner prior to issuing a Rectification Notice.

#### 4.9 **Rectification works**

- (1) The Owner must comply, at its cost, with any Rectification Notice within the period specified in the notice or otherwise agreed period in writing.
- (2) If the Owner fails to comply with a Rectification Notice within the specified or agreed period and the party who issued the Rectification Notice undertakes the works specified in the Rectification Notice in accordance with this Agreement, the Owner must reimburse the relevant party for the cost of those works and any necessary interim or temporary works, including administration costs, within 10 Business Days of the relevant party providing a written demand for payment of those costs.
- (3) In the event that an Owner does not reimburse the relevant party under clause 4.9(2), that Owner authorises the relevant party to lodge a caveat on the lot owned by that Owner.

#### 4.10 **Access**

Subject to compliance with this Agreement, the Owner must allow access to other parties to carry out their obligations under this Agreement.

## 5 **Obligations of the Developer**

### 5.1 **Fencing**

Before the Land is occupied, or within 12 months of execution of this Agreement, whichever occurs earlier, the Developer must construct the Fencing in the location shown in the Location Plan which restricts access to the Backslope.

## 5.2 Landscaping

The Developer must maintain the landscaping that is established on the Backslope, in accordance with the Landscaping Schedule, to the satisfaction of Melbourne Water for five (5) years from the date of this Agreement.

## 5.3 Monitoring

Unless otherwise agreed with Melbourne Water, the Developer must, at its cost, engage a suitably qualified and experienced person approved by Melbourne Water to monitor the Protection Mechanism for any material changes to levels or condition as follows:

- (1) via inspection of aerial photographs – quarterly;
- (2) via physical (on-site) visual inspection of the Land - annually;
- (3) via level survey – biennially, with each Lot to be surveyed within 12 months of issue of a separate certificate of title for the Land and again at intervals of not more than 24 months; and
- (4) via any of the above methods as necessary - whenever it has reason to believe that additional inspection or survey is or may be warranted.

## 5.4 Notification

- (1) Unless otherwise agreed with Melbourne Water, the Developer must, at its cost:
  - (a) notify Melbourne Water as soon as practicable upon becoming aware of any material change in the level of the continuous high point of the Protection Mechanism or any material change in the integrity of the Protection Mechanism;
  - (b) notify Melbourne Water within 10 Business Days of becoming aware of a reason to believe that additional inspection or survey is or may be warranted; and
  - (c) provide a report annually to Melbourne Water describing, in relation to the previous year, the monitoring undertaken in accordance with clause 5.3, the results of monitoring, any rectification works carried out and any rectification work outstanding, with a report to be provided within three months of each anniversary of the date of this Agreement.
- (2) The Developer must, prior to commencement of sales of lots to be created from the Land, undertake the following:
  - (a) notify prospective purchasers of any part of the Land of the obligations in this Agreement;
  - (b) disclose the Agreement in any contract of sale of a lot created from the Land;
  - (c) remind Owners of the obligations in this Agreement during the Developer's building and landscape approval process; and

- (3) The Developer must, on an annual basis, remind Owners of the obligations in this Agreement via a newsletter delivered to all completed dwellings.

## **6 Powers of Melbourne Water and Developer**

### **6.1 Entry onto Land**

- (1) Subject to clause 6.1(2):
  - (a) the Developer may enter the Land for the purposes of monitoring of the kind described in the sub-paragraphs of clause 5.3;
  - (b) Melbourne Water may enter the Land for the purposes of monitoring of the kind described in the sub-paragraphs of clause 5.3;
  - (c) if an Owner fails to comply with a Rectification Notice within the specified or agreed time for compliance, the Developer or Melbourne Water may enter the Land for the purposes of undertaking the works specified in the Rectification Notice and any necessary interim or temporary works.
- (2) A party who wishes to enter the Land pursuant to clause 6.1(1) must provide the following notice in writing to the relevant Owner:
  - (a) if the works are considered urgent – as much notice as reasonably practicable; or
  - (b) in other circumstances – at least 5 Business Days' notice.

## **7 Earlier Agreement**

- 7.1 Upon Commencement of this Agreement, the Earlier Agreement ends.
- 7.2 Upon the ending of the Earlier Agreement the parties agree Melbourne Water will, within a reasonable time, following a request from the Owner or the Developer and at the cost of the Owner, complete and execute all documents necessary to make application to the Registrar of Titles under section 183(2) of the Act to cancel the recording of the Earlier Agreement on the Register.
- 7.3 The Parties acknowledge and agree that this Agreement:
  - (1) supersedes the Earlier Agreement; and
  - (2) satisfies the conditions of the Earlier Permit that necessitated the Earlier Agreement.

## **8 Further Obligations of the Owner**

### **8.1 Notice**

The Owner must bring this Agreement to the attention of all prospective purchasers, mortgagees, transferees and assigns. This obligation is in addition to the obligations of clause 4.7(1).

### **8.2 Mortgagee to be bound**

The Owner must obtain the consent of any mortgagee to be bound by the covenants in this Agreement if the Mortgagee becomes mortgagee in possession of the Land.

### 8.3 **Registration of Agreement**

The Owner must do all things necessary to enable Melbourne Water to make an application to the Registrar of Titles to make a recording of this Agreement on the Certificate of Title to the Land in accordance with section 181 of the Act including the signing of any further agreement, acknowledgement or other document.

### 8.4 **Melbourne Water's Costs to be paid**

The Owner must pay immediately on demand the reasonable costs of Melbourne Water of and incidental to the preparation, execution and registration of this Agreement.

## **9 Indemnities**

9.1 The Developer indemnifies Melbourne Water against all costs, expenses, losses or damages Melbourne Water may sustain, incur, suffer, or be or become liable for in respect of any suit, action, proceeding, judgement or claim brought by any person arising from or referable to:

- (1) this Agreement; or
- (2) a breach or non-performance of any of the obligations of the Developer under this Agreement

to the extent that any costs, expenses, losses or damages arise from a wilful or negligent act of the Developer or non-compliance with this Agreement by the Developer.

9.2 The Owner indemnifies Melbourne Water against all costs, expenses, losses or damages Melbourne Water may sustain, incur, suffer, or be or become liable for in respect of any suit, action, proceeding, judgement or claim brought by any person arising from or referable to:

- (1) this Agreement; or
- (2) a breach or non-performance of any of the obligations of the Owner under this Agreement

to the extent that any costs, expenses, losses or damages arise from a wilful or negligent act of the Owner or non-compliance with this Agreement by the Owner.

9.3 The Owner indemnifies the Developer against all costs, expenses, losses or damages the Developer may sustain, incur, suffer, or be or become liable for in respect of any suit, action, proceeding, judgement or claim brought by any person arising from or referable to:

- (1) this Agreement; or
- (2) a breach or non-performance of any of the obligations of the Owner under this Agreement

to the extent that any costs, expenses, losses or damages arise from a wilful or negligent act of the Owner or non-compliance with this Agreement by the Owner.

## **10 Further assurance**

Each party must promptly at its own cost do all things (including executing and if necessary delivering all documents) necessary or desirable to give full effect to this Agreement.

## **11 Agreement under section 173 of the Act**

The parties acknowledge and agree that this Agreement:

- (1) is made under section 173 of the Act; and
- (2) in addition operates as a deed between the parties.

## **12 Owner's warranties**

Without limiting the operation or effect which this Agreement has, the Owner warrants that apart from the Owner and any other person who has consented in writing to this Agreement, no other person has any interest, either legal or equitable, in the Land.

## **13 Planning objectives**

The parties acknowledge that the provisions of this Agreement are intended to achieve or advance the objectives of planning in Victoria and the objectives of the Planning Scheme.

## **14 Successors in title**

Without limiting the operation or effect which this Agreement has, the Owner must ensure that, until such time as a memorandum of this Agreement is registered on the title to the Land, successors in title must be required to:

- (1) give effect to and do all acts and sign all documents which will require those successors to give effect to this Agreement; and
- (2) execute a deed agreeing to be bound by the terms of this Agreement.

## **15 Goods and Service Tax**

### **15.1 Definitions and Expressions**

Expressions used in this Agreement that are defined in the *GST Act* have the same meaning as given to them in the *GST Act*, unless expressed to the contrary.

### **15.2 Amounts payable do not include GST**

Each amount, of whatever description, specified as payable by one party to the other party under this Agreement is expressed as a GST exclusive amount unless specified to the contrary.

### **15.3 Liability to pay any GST**

Subject to clause 15.4, in addition to any amount payable by one party to the other party under this Agreement in respect of a taxable supply, the party liable to pay the amount ("Recipient") must pay to the other party ("Supplier") a sum equivalent to the GST payable,

if any, by the Supplier in respect of the taxable supply on the date on which the amount is otherwise payable.

#### **15.4 Tax Invoice**

A party's right to payment under clause 15.3 is subject to a Tax Invoice being delivered to the Recipient.

## **16 General Matters**

### **16.1 Service of Notice**

A notice or other communication required or permitted to be served by a party on another party must be in writing and in addition to any other method of service provided by law may be served:

- (1) by delivering it personally on that party; or
- (2) by sending it by priority pre paid post, addressed to that party at the address set out in this Agreement or subsequently notified to each party; or
- (3) by sending it by facsimile if it confirmed immediately in writing by the sending party by hand delivery or pre paid post.

### **16.2 Time of Service**

A notice or other communication is deemed served:

- (1) if delivered personally, on the next following business day;
- (2) if posted within Australia to an Australian address, two business days after the date of posting and in any other case, seven business days after the date of posting;
- (3) if sent by facsimile, on the next following business day unless the receiving party has requested retransmission before the end of that day;
- (4) if received after 6.00pm in the place of receipt or on a day which is not a business day, at 9.00am on the next business day.

### **16.3 No Waiver**

Any time or other indulgence granted by Melbourne Water to the Owner or the Developer or any variation of the terms and conditions of this Agreement or any judgement or order obtained by Melbourne Water against the Owner or the Developer do not in any way amount to a waiver of any of the rights or remedies of Melbourne Water in relation to the terms of this Agreement.

### **16.4 Jurisdiction**

- (1) The law of Victoria governs this Agreement.
- (2) The parties submit to the non-exclusive jurisdiction of the courts of Victoria and of the Commonwealth of Australia.

### **16.5 Severability**

If a court, arbitrator, tribunal or other competent authority determines that a word, phrase, sentence, paragraph or clause of this Agreement is unenforceable, illegal or void then it must be severed and the other provisions of this Agreement remain operative.

## 16.6 Disputes

- (1) If there is a dispute between the parties concerning the interpretation or implementation of this Agreement, that dispute may be referred to the Tribunal for resolution to the extent permitted by the Act.
- (2) If there is a dispute concerning any matter which is not referable to the Tribunal under the Act, that dispute may be referred for arbitration by an Arbitrator agreed upon in writing by the parties or, in the absence of such agreement the Chair of the Resolution Institute or his/her nominee, for arbitration.
- (3) Where provision is made in this Agreement that any matter be done to the satisfaction of Melbourne Water or any of its officers and a dispute arises in relation to such provision, the dispute may be referred to the Tribunal in accordance with section 149(1)(b) of the Act.
- (4) The parties are be entitled to legal representation for the purposes of any arbitration or referral referred to in clauses (2) and (3). Unless the Arbitrator, Chairman, nominee or the Tribunal otherwise directs, each party must bear its own costs.

## 16.7 No Fettering of Melbourne Water's powers

The parties acknowledge and agree that this Agreement does not fetter or restrict the power or discretion of Melbourne Water to make any decision or impose any requirements or conditions in connection with the granting of any planning approval or certification of any plans of subdivision applicable to the Land or relating to any use or development of the Land.

## 16.8 Assignment

The Developer may assign or otherwise deal with this Agreement subject to the proposed assignee agreeing in writing with Melbourne Water to comply with this Agreement as if it were an original party to this Agreement.

## 17 Commencement of Agreement

Unless otherwise provided in this Agreement, this Agreement commences from the date of this Agreement.

## 18 Amendment

18.1 The Agreement may be amended:

- (1) when all of the parties agree in writing to amend the Agreement wholly or in part as to any part of the Land; or
- (2) otherwise in accordance with Part 9 Division 2 of the Act.

18.2 If notice of a proposal to amend this Agreement is required pursuant to Section 178C of the Act, the parties agree that only Melbourne Water and the Owner of the Land or that part of the Land that is the subject of the proposal to amend this Agreement, are required to be notified of the proposal, pursuant to section 178C(3) of the Act.

- 18.3 Where it is proposed to amend this Agreement in relation to part of the Land by agreement, the parties agree that only Melbourne Water and the Owner of the part of the Land that is the subject of the proposal to amend this Agreement are required to agree to the amendment, and the agreement of other Owners of the Land is not required.

## **19 Ending of Agreement**

- 19.1 This Agreement comes to an end within the meaning of section 177(1) of the Act upon the earlier of:
- (1) the final section of the permanent reservoir protection mechanism, shown as “bund C” on the Permanent Reservoir Protection Plan has been constructed to Melbourne Water’s satisfaction; or
  - (2) the parties agree in writing to end the Agreement wholly or in part or as to any part of the Land in accordance with section 177(2) of the Act; or
  - (3) a decision to end the Agreement is made under Part 9 Division 2 of the Act.
- 19.2 Once this Agreement ends, Melbourne Water will, within a reasonable time, following a request from the Owner or the Developer and at the cost of the Owner, complete and execute all documents necessary to make application to the Registrar of Titles under section 183(2) of the Act to cancel the recording of this Agreement on the Register.
- 19.3 Where it is proposed to end this Agreement in relation to part of the Land by agreement, the parties agree that only Melbourne Water and the Owner of the part of the Land that is the subject of the proposal to end this Agreement are required to agree to the ending, and the agreement of other Owners of the Land is not required.
- 19.4 If notice of a proposal to end this Agreement is required pursuant to Section 178C of the Act, the parties agree that only Melbourne Water and the Owner of the Land or that part of the Land that is the subject of the proposal to amend this Agreement, are required to be notified of the proposal pursuant to section 178C(3) of the Act.
- 19.5 The rights and obligations of the Developer under this Agreement come to an end when the Agreement comes to an end or 15 years from commencement of this Agreement, whichever occurs earlier.

## **20 Counterparts**

This Agreement may be executed in counterparts. Each counterpart is an original but the counterparts together are one and the same agreement. This Agreement is binding on the parties on the exchange of the executed counterparts. A copy of the original executed counterpart sent by facsimile machine or email:

- (1) must be treated as an original counterpart;
- (2) is sufficient evidence of the execution of the original; and
- (3) may be produced in evidence for all purposes in place of the original.



# Appendix 1 - Location Plan - Backslope and Fencing



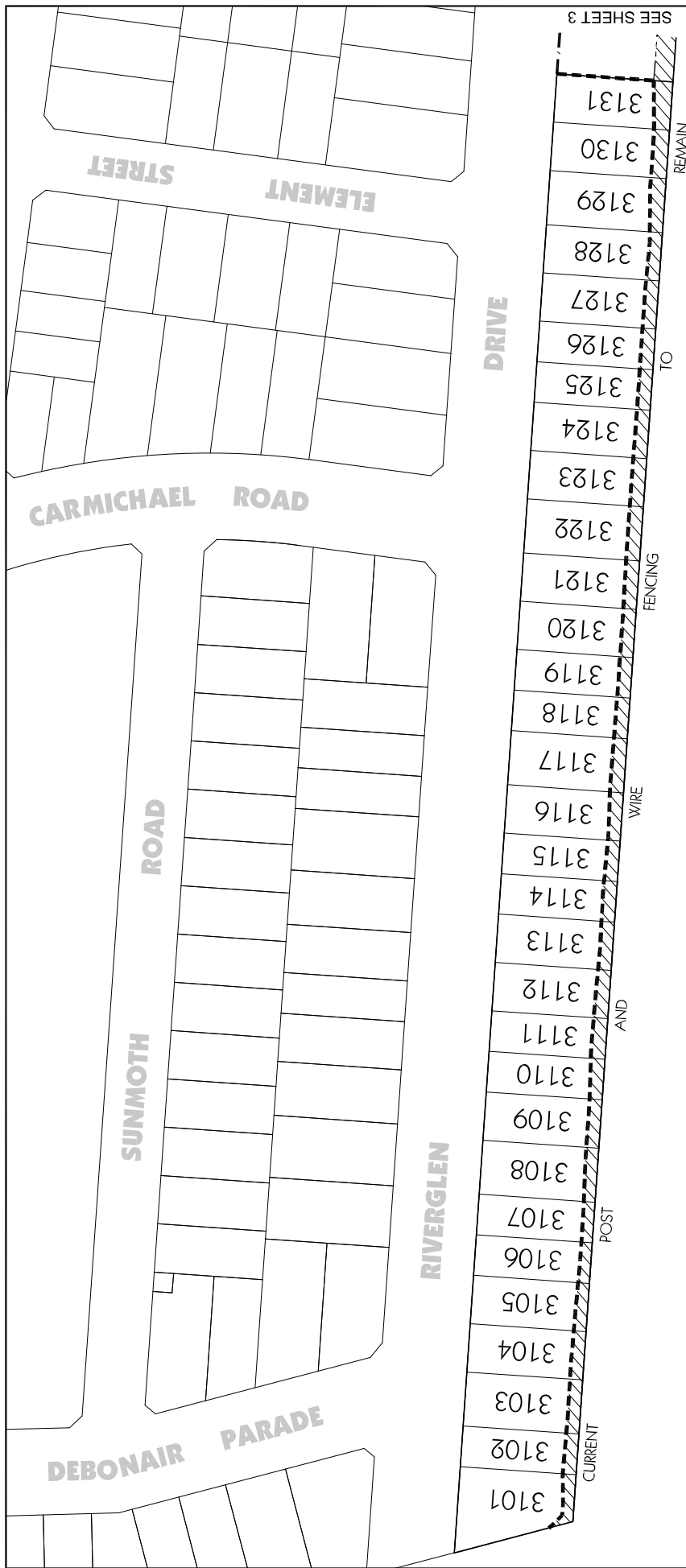

**LEGEND & NOTATIONS**

- //// Backslope
- Continuous High Point
- Colorbond Fence (will be constructed by Peet along the Continuous High Point at the rear of all Stage 31 lots).
- Post & Wire Fence (with gate for access to the Bund and Backslope) will be constructed by Peet.

Colorbond Fencing will be constructed by Purchasers along all Stage 31 side lot boundaries, from the lot frontage to the Colorbond Fence on the Continuous High Point.



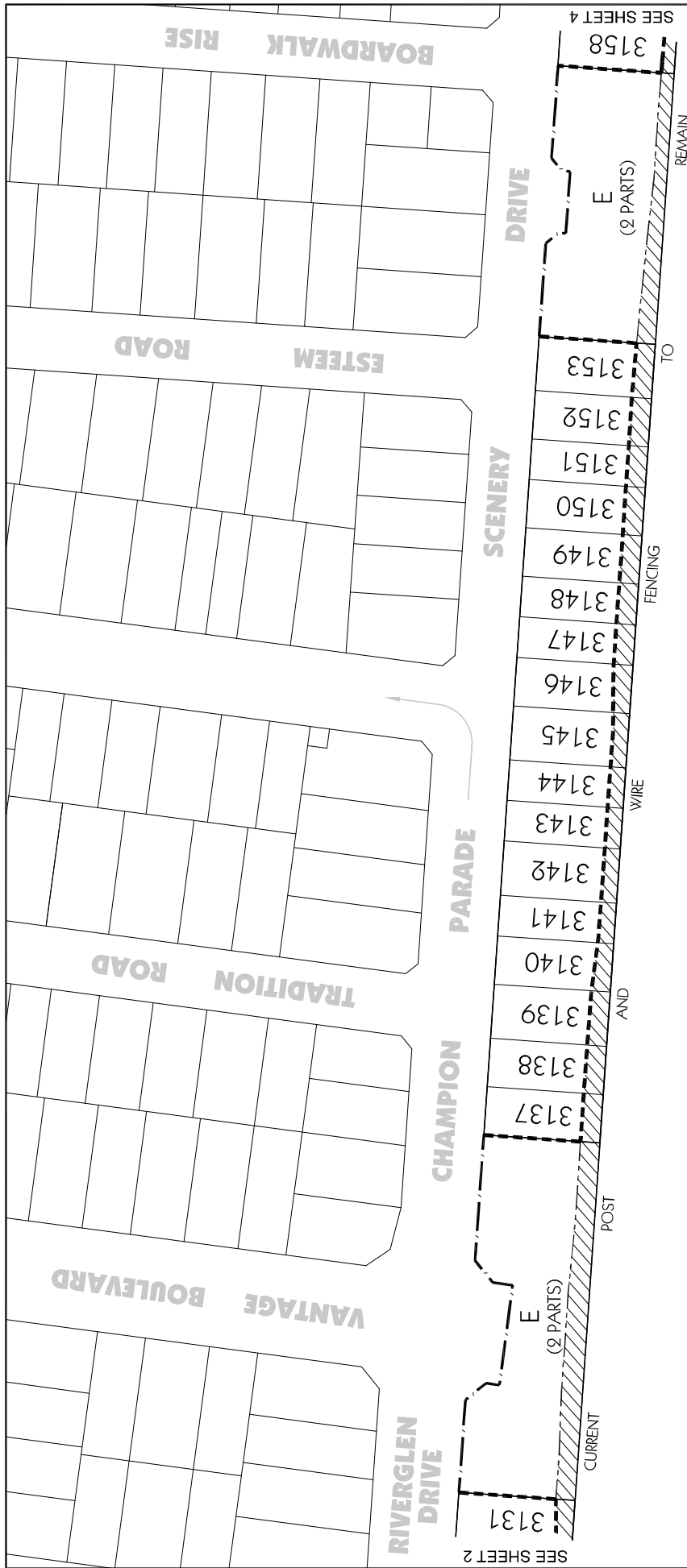

**LEGEND & NOTATIONS**

- //// Backslope
- Continuous High Point
- Colorbond Fence (will be constructed by Peet along the Continuous High Point at the rear of all Stage 31 lots).
- Post & Wire Fence (with gate for access to the Bund and Backslope) will be constructed by Peet.

Colorbond Fencing will be constructed by Purchasers along all Stage 31 side lot boundaries, from the lot frontage to the Colorbond Fence on the Continuous High Point.



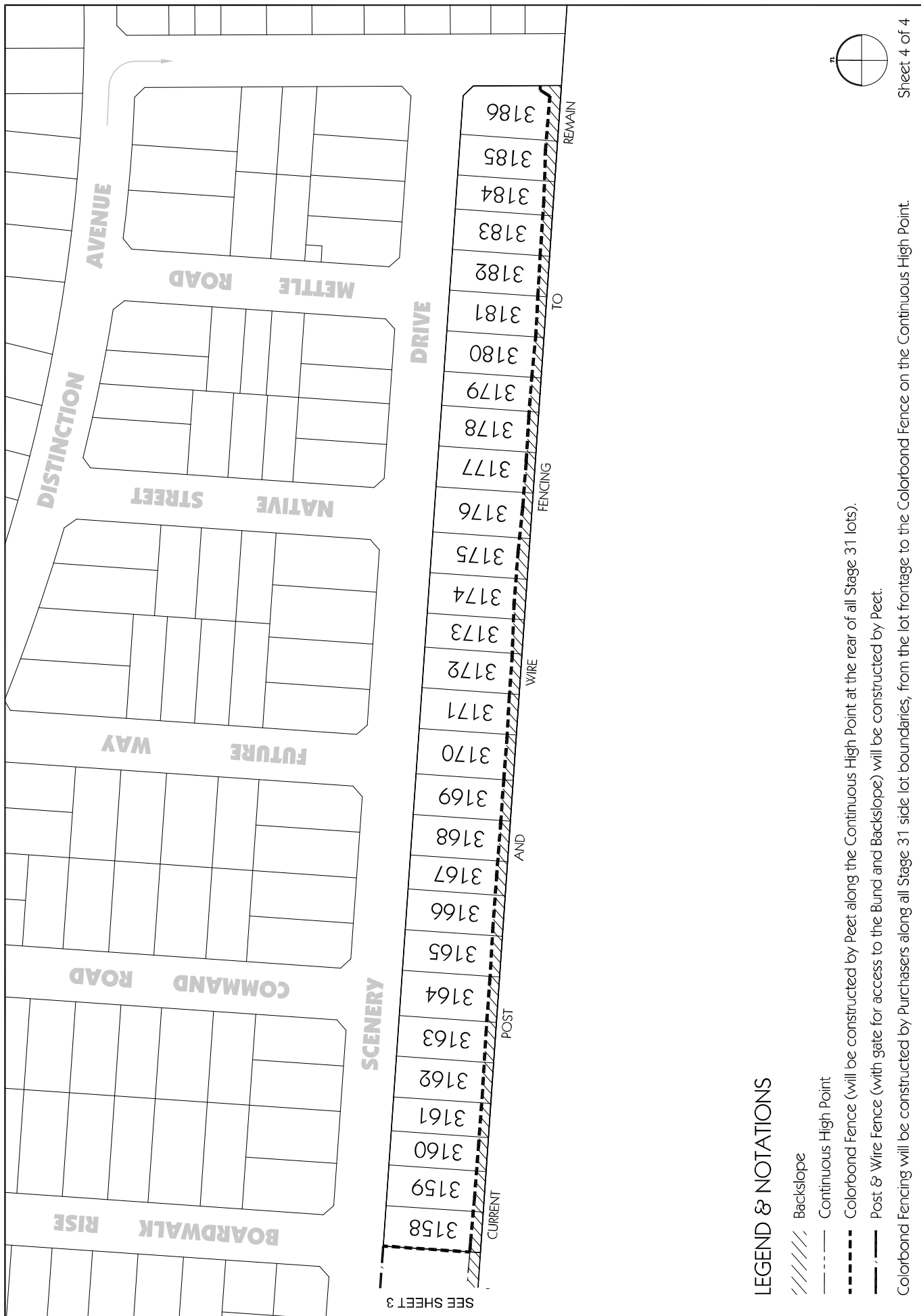



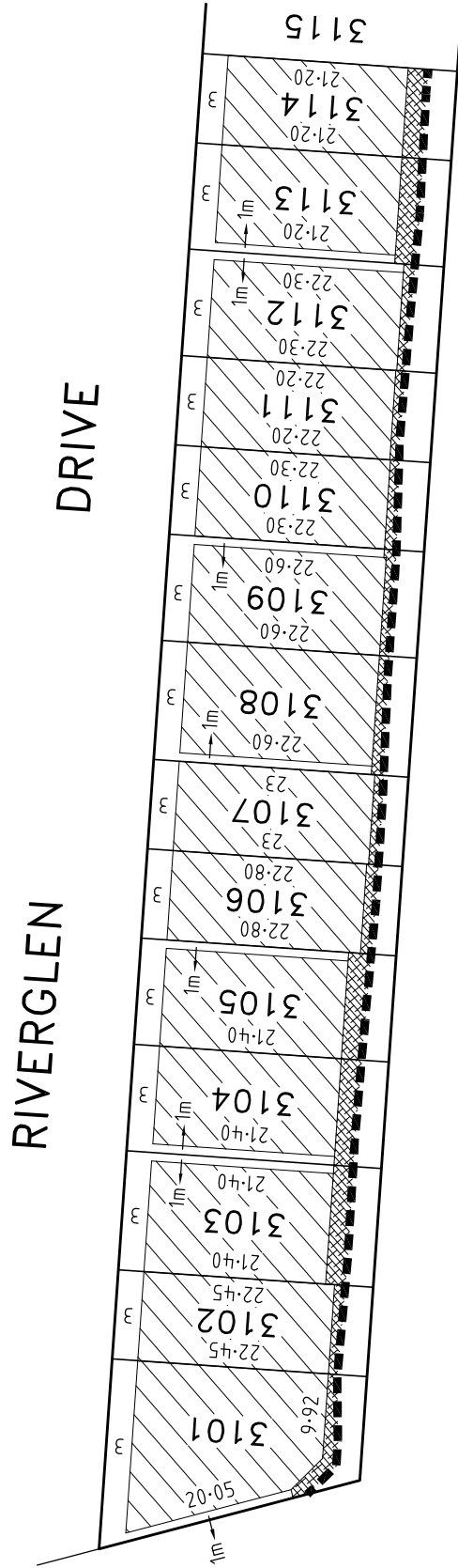
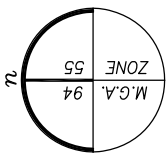

# Appendix 2 - Building Zones Plan

BUILDING ZONES PLAN  
SHEET 1 OF 6



-  Building Envelope Zone 1
-  Building Envelope Zone 2 (Engineered Footing Zone)
-  Exclusion Zone
-  Backslope Fence



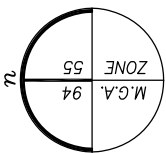

SEE SHEET 2

BUILDING ZONES PLAN  
SHEET 2 OF 6

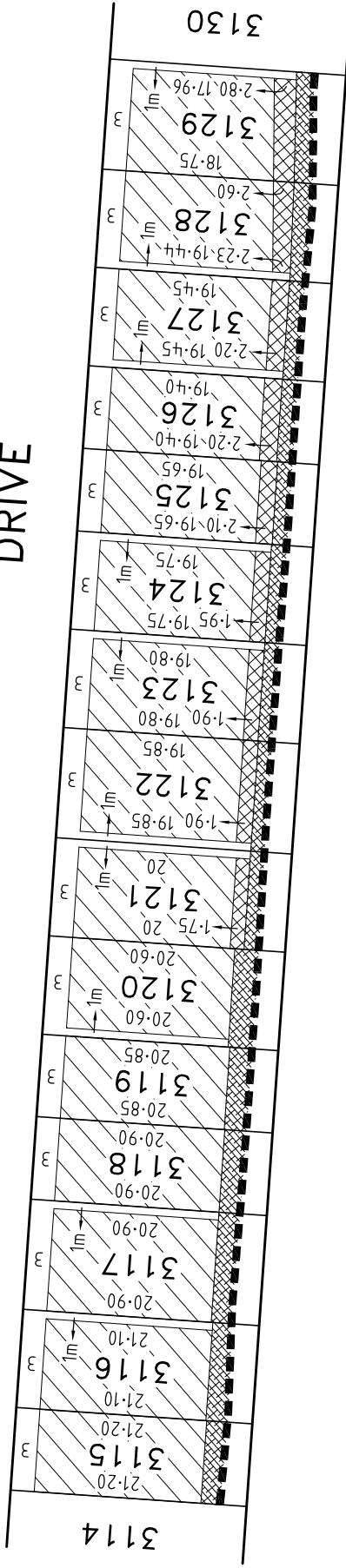

RIVERGLEN DRIVE



-  Building Envelope Zone 1
-  Building Envelope Zone 2 (Engineered Footing Zone)
-  Exclusion Zone
-  Backslope Fence

SEE SHEET 1

SEE SHEET 3

BUILDING ZONES PLAN  
SHEET 3 OF 6

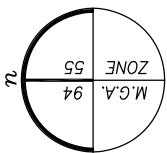

VANTAGE  
BOULEVARD



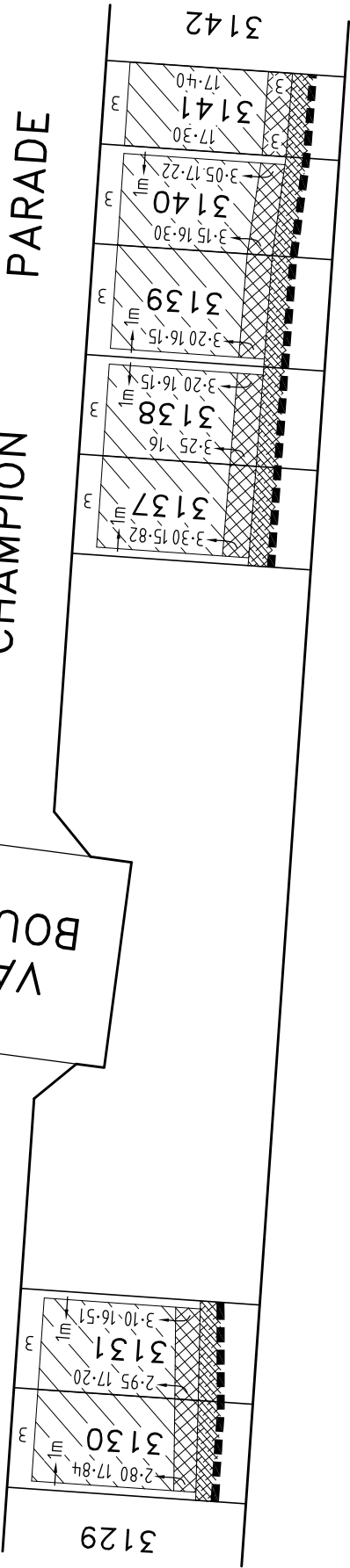

RIVERGLEN DRIVE

CHAMPION PARADE



SEE SHEET 2

SEE SHEET 4

-  Building Envelope Zone 1
-  Building Envelope Zone 2 (Engineered Footing Zone)
-  Exclusion Zone
-  Backslope Fence

BUILDING ZONES PLAN  
SHEET 4 OF 6

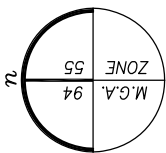

CHAMPION  
PARADE





SCENERY

DRIVE

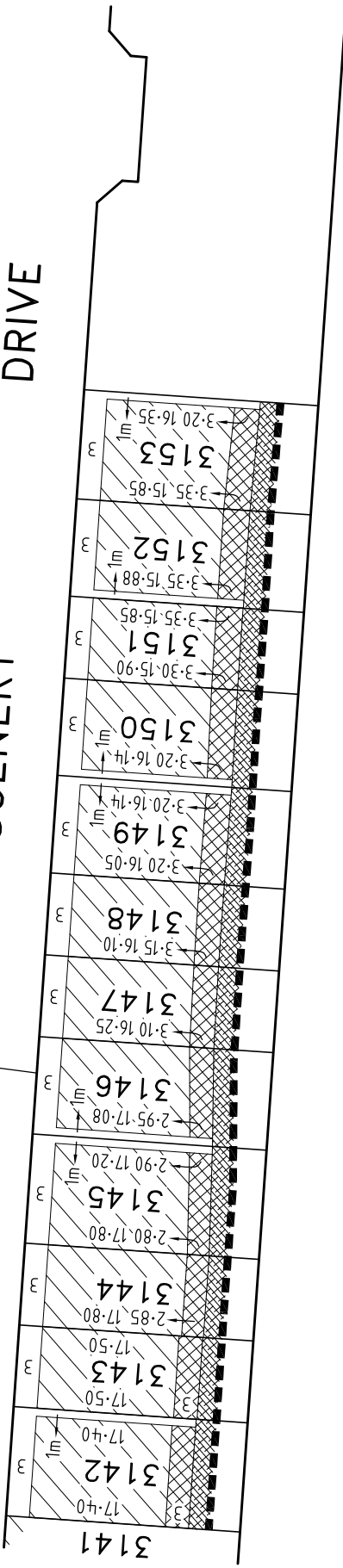
SEE SHEET 3

SEE SHEET 5







-  Building Envelope Zone 1
-  Building Envelope Zone 2 (Engineered Footing Zone)
-  Exclusion Zone
-  Backslope Fence

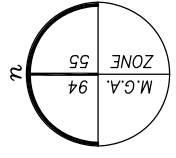
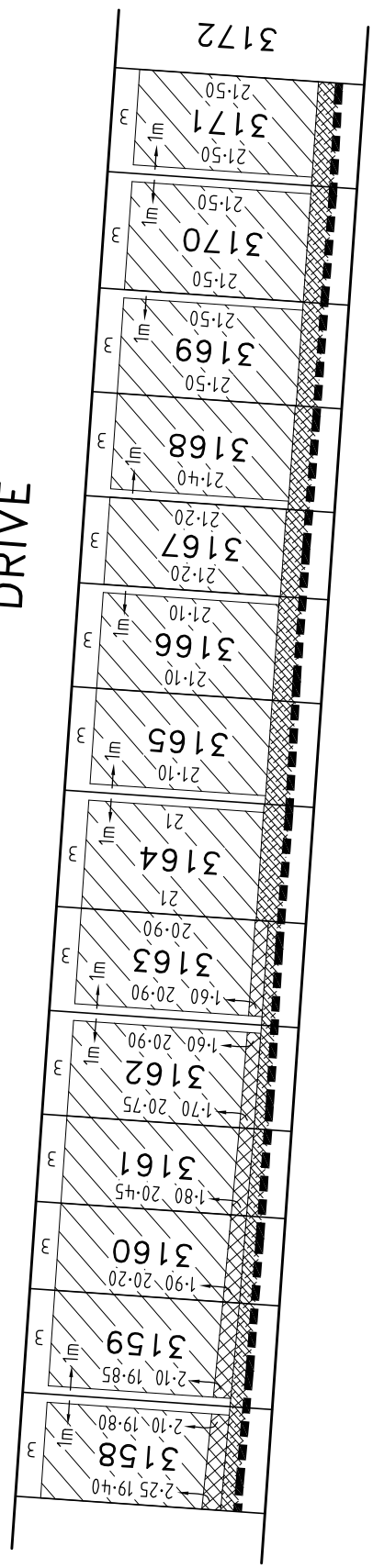

BUILDING ZONES PLAN  
SHEET 5 OF 6

SCENERY DRIVE



-  Building Envelope Zone 1
-  Building Envelope Zone 2 (Engineered Footing Zone)
-  Exclusion Zone
-  Backslope Fence



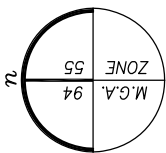

BUILDING ZONES PLAN  
SHEET 6 OF 6

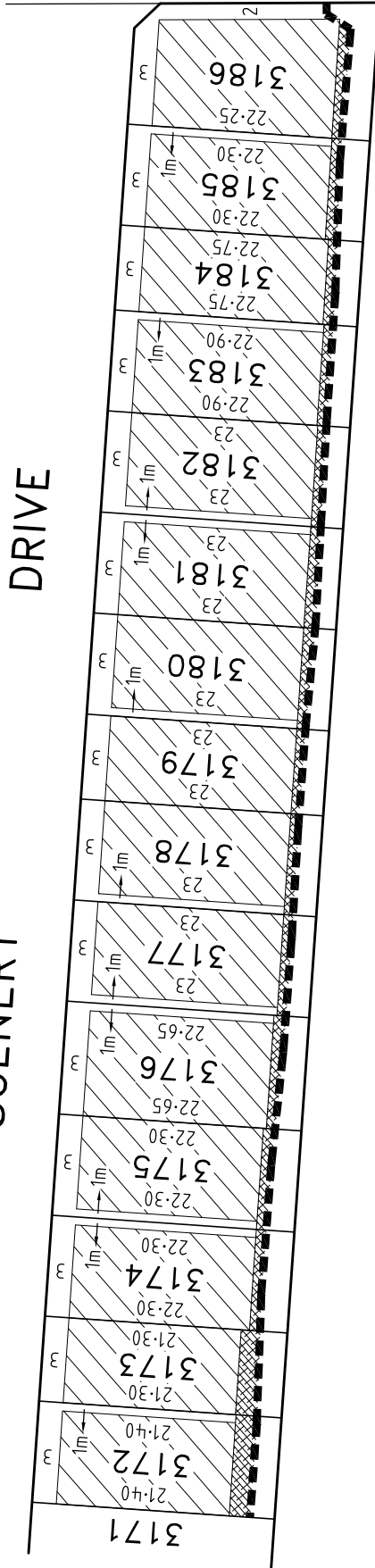

DISTINCTION AVENUE



SCENERY DRIVE

-  Building Envelope Zone 1
-  Building Envelope Zone 2 (Engineered Footing Zone)
-  Exclusion Zone
-  Backslope Fence

SEE SHEET 5

## Appendix 3 - Landscaping Schedule

**ASTON STAGE 31 BUND, RIVERGLEN DRIVE,  
CRAIGIEBURN BACKSLOPE LANDSCAPE MAINTENANCE  
SCHEDULE**

**Schedule 1 - Particulars**

**Schedule 2 - Developer's Maintenance Works**

**Annexure A - Backslope Landscaping Plan**

**Annexure B - Priority Weed Species List**

## SCHEDULE 1

### 1. COMMENCEMENT DATE

- (a) Peet's Commencement Date: The date as shown on Council's letter of Statement of Compliance for Stage 31
- (b) Melbourne Water's Commencement Date: N/A

### 2. DEVELOPER

Peet Craigieburn Pty Ltd

### 3. DESCRIPTION OF THE LAND

The location of the site is shown in Figure 1 following. The Stage 31 Bund is located on the southern boundary of the Aston development at 575 Craigieburn Road, Craigieburn



Figure 1.

### 4. OWNER OF THE LAND

- (a) Peet Craigieburn Pty Ltd.

### 5. SPECIAL CONDITIONS

- (a) No Special Conditions

**SCHEDULE 2 - DEVELOPER'S MAINTENANCE WORKS – BACKSLOPE ONLY**

<b>Description</b>	<b>Assets</b>	<b>Maintenance Works</b>	<b>Frequency of Maintenance Works</b>
Backslope Landscaping	Native Shrubs & Grasses	Removal of litter & weed management	Twice yearly or as required

**ANNEXURE A - BACKSLOPE LANDSCAPING PLAN**

# PEET - ASTON

## STAGE 31 BUND PLANTING

### RIVERGLEN & SCENERY DRIVE > CRAIGIEBURN

### LANDSCAPE CONSTRUCTION DOCUMENTATION

## DRAWING REGISTER

- L0 > TITLE PAGE, CONTEXT PLAN AND PLANT SCHEDULE
- L1 > BUND SETOUT PLANS
- L2 > BUND PLANTING DETAILS AND BUND SETOUT SCHEDULE
- L3 > BUND DETAILS

### PLANT SCHEDULE

CODE	BOTANICAL NAME	COMMON NAME	H X W	DENSITY	INSTALL SIZE	QTY.
<b>SHRUBS</b>						
AA	ACACIA ACINGEA	GOLD DUST WATTLE	2 X 2M	AS SHOWN	TUBESTOCK	877
GR	GREVILLEA ROBINIFOLIA	ROSEMARY GREVILLEA	2 X 2M	AS SHOWN	TUBESTOCK	854
<b>GROUNDCOVERS &amp; GRASSES</b>						
FN	FLAX-LILY	FLAX-LILY	1 X 1M	4M2	TUBESTOCK	1765
PN	POINSETTIA	KIMBERLY CLUB RUSH	1 X 1M	4M2	TUBESTOCK	1148
LL	LOMANDEA LONGIFOLIA	SPRINGHEADED MAT RUSH	1 X 1M	3M2	TUBESTOCK	2872
RP	RIVACOLA PARVIFOLIA	FRAGRANT SALT BUSH	1 X 2M	3M2	TUBESTOCK	2319
<b>TOTAL</b>						<b>10,327</b>



<b>PROJECT</b> PEET - ASTON RIVERGLEN & SCENERY DRIVE > CRAIGIEBURN	<b>NOT DATE</b> MAY 2019	<b>PROJECT NO.</b> 13038	<b>REV.</b> A
<b>TITLE</b> STAGE 31 BUND PLANTING	<b>SCALE</b> 1:1000 @ A1	<b>DRAWN</b> [Name]	<b>DATE</b> [Date]
<b>LANDSCAPE CONSTRUCTION DOCUMENTATION</b>			
<b>TITLE PAGE, CONTEXT PLAN &amp; PLANT SCHEDULE</b>			

**URBAN EDGE**  
LANDSCAPE ARCHITECTS

Level 2, 20 Market Street  
Sydney NSW 2000  
t: +61 2 9550 9000  
e: info@urbanedgearchitects.com.au

**aston**  
www.aston.com.au

**PEET**

**NOT FOR CONSTRUCTION**

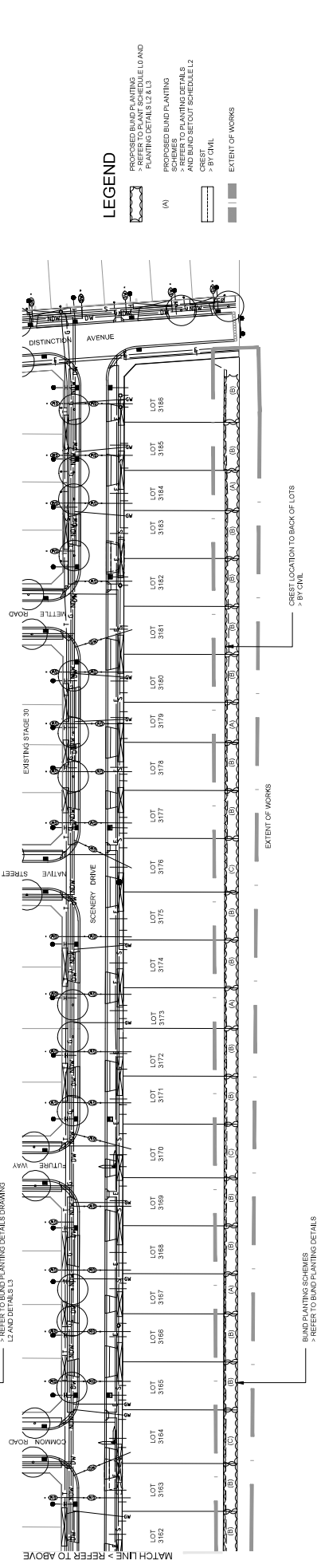
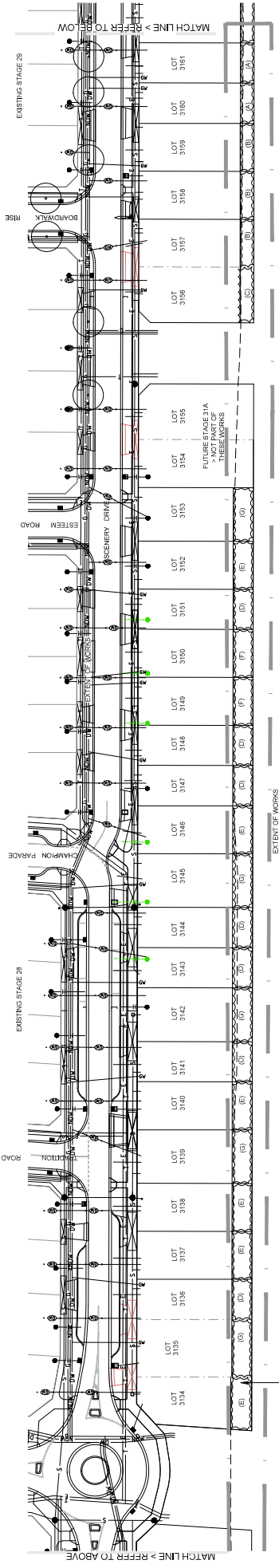
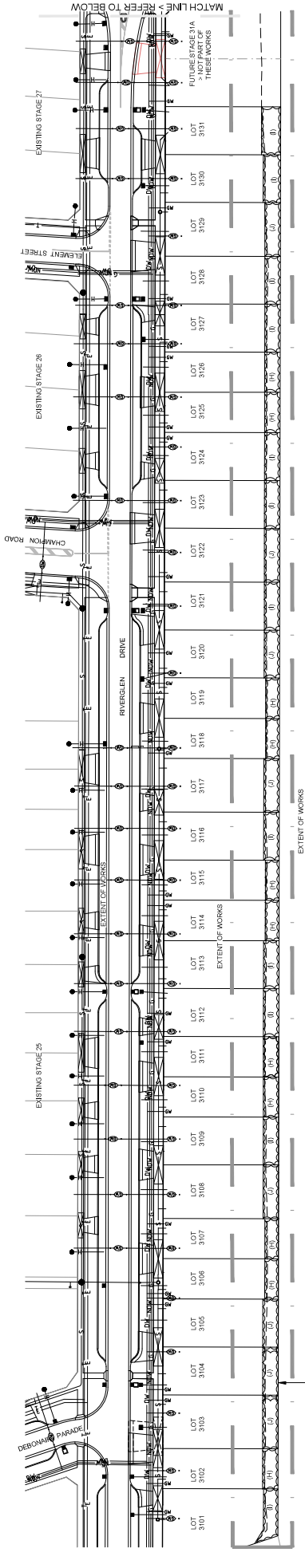

**LEGEND**

PROPOSED BAND PLANTING  
> REFER TO PLANT SCHEDULE L2 AND L3

PLANTING DETAILS L2 & L3

PROPOSED BAND PLANTING SCHEMES TO PLANTING DETAILS AND BAND SETOUT SCHEDULE L2

CREST > BY CIVIL

EXTENT OF WORKS

URBAN EDGE LANDSCAPE ARCHITECTS  
100/102/104/106/108/110/112/114/116/118/120/122/124/126/128/130/132/134/136/138/140/142/144/146/148/150/152/154/156/158/160/162/164/166/168/170/172/174/176/178/180/182/184/186/188/190/192/194/196/198/200/202/204/206/208/210/212/214/216/218/220/222/224/226/228/230/232/234/236/238/240/242/244/246/248/250/252/254/256/258/260/262/264/266/268/270/272/274/276/278/280/282/284/286/288/290/292/294/296/298/300/302/304/306/308/310/312/314/316/318/320/322/324/326/328/330/332/334/336/338/340/342/344/346/348/350/352/354/356/358/360/362/364/366/368/370/372/374/376/378/380/382/384/386/388/390/392/394/396/398/400/402/404/406/408/410/412/414/416/418/420/422/424/426/428/430/432/434/436/438/440/442/444/446/448/450/452/454/456/458/460/462/464/466/468/470/472/474/476/478/480/482/484/486/488/490/492/494/496/498/500/502/504/506/508/510/512/514/516/518/520/522/524/526/528/530/532/534/536/538/540/542/544/546/548/550/552/554/556/558/560/562/564/566/568/570/572/574/576/578/580/582/584/586/588/590/592/594/596/598/600/602/604/606/608/610/612/614/616/618/620/622/624/626/628/630/632/634/636/638/640/642/644/646/648/650/652/654/656/658/660/662/664/666/668/670/672/674/676/678/680/682/684/686/688/690/692/694/696/698/700/702/704/706/708/710/712/714/716/718/720/722/724/726/728/730/732/734/736/738/740/742/744/746/748/750/752/754/756/758/760/762/764/766/768/770/772/774/776/778/780/782/784/786/788/790/792/794/796/798/800/802/804/806/808/810/812/814/816/818/820/822/824/826/828/830/832/834/836/838/840/842/844/846/848/850/852/854/856/858/860/862/864/866/868/870/872/874/876/878/880/882/884/886/888/890/892/894/896/898/900/902/904/906/908/910/912/914/916/918/920/922/924/926/928/930/932/934/936/938/940/942/944/946/948/950/952/954/956/958/960/962/964/966/968/970/972/974/976/978/980/982/984/986/988/990/992/994/996/998/1000

PEET - ASTON RIVERGLEN & SCENERY DRIVE > CRAIGBURN  
STAGE 31 BAND PLANTING  
LANDSCAPE CONSTRUCTION DOCUMENTATION  
BAND SETOUT PLANS

NOT FOR CONSTRUCTION

aston PEET  
www.astonpeet.com.au

URBAN EDGE LANDSCAPE ARCHITECTS  
100/102/104/106/108/110/112/114/116/118/120/122/124/126/128/130/132/134/136/138/140/142/144/146/148/150/152/154/156/158/160/162/164/166/168/170/172/174/176/178/180/182/184/186/188/190/192/194/196/198/200/202/204/206/208/210/212/214/216/218/220/222/224/226/228/230/232/234/236/238/240/242/244/246/248/250/252/254/256/258/260/262/264/266/268/270/272/274/276/278/280/282/284/286/288/290/292/294/296/298/300/302/304/306/308/310/312/314/316/318/320/322/324/326/328/330/332/334/336/338/340/342/344/346/348/350/352/354/356/358/360/362/364/366/368/370/372/374/376/378/380/382/384/386/388/390/392/394/396/398/400/402/404/406/408/410/412/414/416/418/420/422/424/426/428/430/432/434/436/438/440/442/444/446/448/450/452/454/456/458/460/462/464/466/468/470/472/474/476/478/480/482/484/486/488/490/492/494/496/498/500/502/504/506/508/510/512/514/516/518/520/522/524/526/528/530/532/534/536/538/540/542/544/546/548/550/552/554/556/558/560/562/564/566/568/570/572/574/576/578/580/582/584/586/588/590/592/594/596/598/600/602/604/606/608/610/612/614/616/618/620/622/624/626/628/630/632/634/636/638/640/642/644/646/648/650/652/654/656/658/660/662/664/666/668/670/672/674/676/678/680/682/684/686/688/690/692/694/696/698/700/702/704/706/708/710/712/714/716/718/720/722/724/726/728/730/732/734/736/738/740/742/744/746/748/750/752/754/756/758/760/762/764/766/768/770/772/774/776/778/780/782/784/786/788/790/792/794/796/798/800/802/804/806/808/810/812/814/816/818/820/822/824/826/828/830/832/834/836/838/840/842/844/846/848/850/852/854/856/858/860/862/864/866/868/870/872/874/876/878/880/882/884/886/888/890/892/894/896/898/900/902/904/906/908/910/912/914/916/918/920/922/924/926/928/930/932/934/936/938/940/942/944/946/948/950/952/954/956/958/960/962/964/966/968/970/972/974/976/978/980/982/984/986/988/990/992/994/996/998/1000

DATE: 2019.05.13  
SCALE: AS SHOWN  
DRAWN BY: [Name]  
CHECKED BY: [Name]  
APPROVED BY: [Name]

NOT DATE: 1008 PAGE 31 BAND  
PROJECT NO: 13038  
DRAWN BY: [Name]  
CHECKED BY: [Name]  
APPROVED BY: [Name]

MAY 2019

1:1 A



**LEGEND**

- PROPOSED INDIGENOUS SHRUBS TO BUND
- SETOUT SCHEDULE L2 & BUND DETAILS L3
- CREST OF BUND
- > BY CIVIL

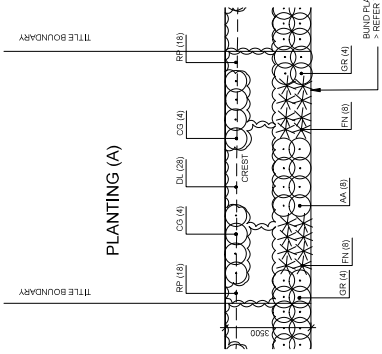

**1 - L2 BUND DETAILS (TYP GARDENBED) 3.5M**

PLAN  
SCALE 1:100

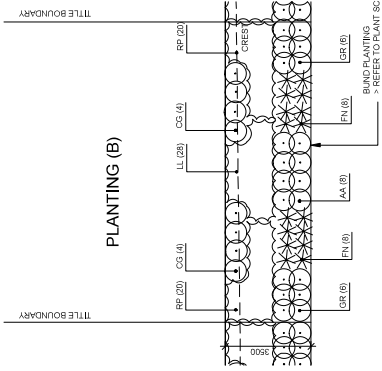

**PLANTING (B)**

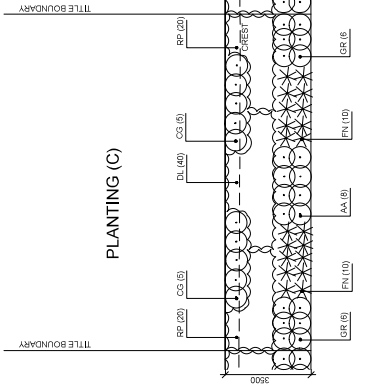

**PLANTING (C)**

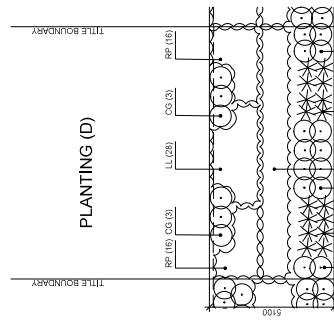

**PLANTING (D)**

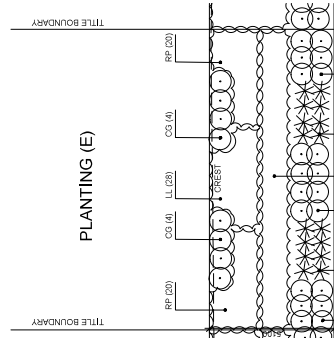

**PLANTING (E)**

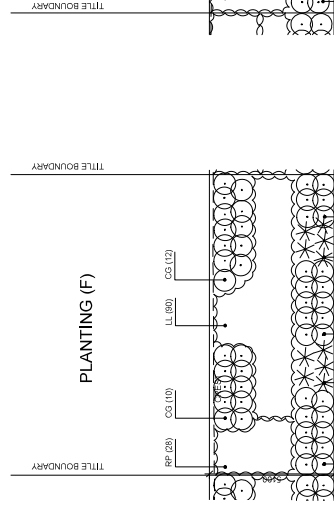

**PLANTING (F)**

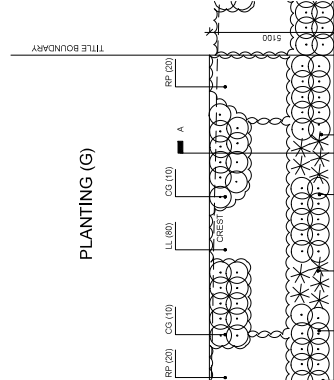

**PLANTING (G)**

**2 - L2 BUND DETAIL (TYP GARDENBED) 5.1M**

PLAN  
SCALE 1:100

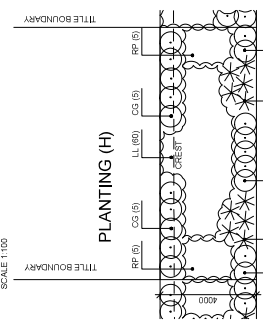

**PLANTING (H)**

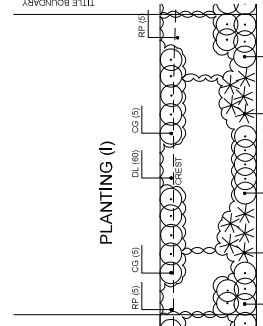

**PLANTING (I)**

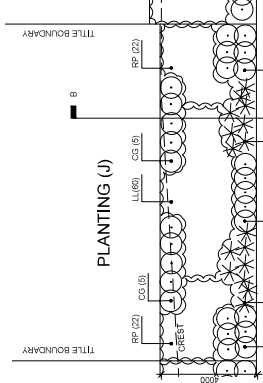

**PLANTING (J)**

**BUND SETOUT SCHEDULE**

CODE	NO. X LOT SIZE
<b>3.5M WIDE GARDENBED TO BUND</b>	
A	6 X 10.5M WIDE LOTS
B	2 X 12.5M WIDE LOTS
C	2 X 12.5M WIDE LOTS
<b>5.1M WIDE GARDENBED TO BUND</b>	
D	7 X 10.5M WIDE LOTS
E	6 X 12.5M WIDE LOTS
F	5 X 14M WIDE LOTS
G	5 X 14M WIDE LOTS
<b>4 M WIDE GARDENBED TO BUND</b>	
H	11 X 10.5M WIDE LOTS
I	12 X 12.5M WIDE LOTS
J	9 X 14.5M WIDE LOTS

**3 - L2 BUND DETAIL (TYP GARDENBED) 4 M**

PLAN  
SCALE 1:100

**URBAN EDGE**  
 LANDSCAPE ARCHITECTS  
 Level 1, 100/105 Sturt Street  
 Adelaide, SA 5000  
 T: 08 8200 8300  
 F: 08 8200 8305  
 www.urbanedge.com.au

**aston**  
 www.aston.com.au

NOT FOR CONSTRUCTION

PROJECT: PEET - ASTON RIVERGLEN & SCENERY DRIVE - CRAIBEBURN  
 TITLE: STAGE 31 BUND PLANTING LANDSCAPE CONSTRUCTION DOCUMENTATION  
 DRAWN: JAMES WILSON  
 DATE: 13/03/20  
 PROJECT NO: 13038  
 SHEET NO: L2  
 OF: A

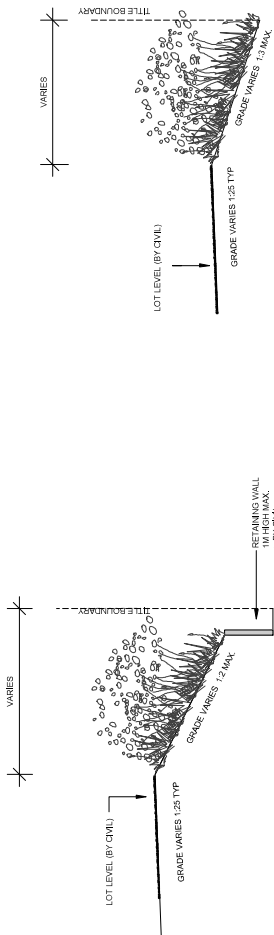

1 - L3 BUND DETAIL WALL (TYPICAL)  
SECTION A - A'  
SCALE 1:50

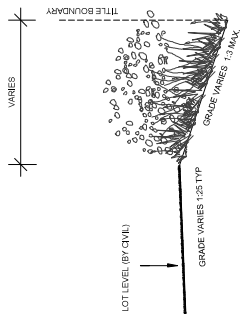

2 - L3 BUND DETAIL (TYPICAL)  
SECTION B - B'  
SCALE 1:50

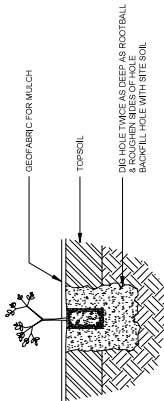

3 - L4 TUBESTOCK PLANTING DETAIL  
SECTION  
SCALE 1:10 @ A3

REVISION	DATE	BY	CHK	APP	DATE
A -					2019.05.13
SUBMITTED TO CLIENT/COUNCIL					
DATE					
DRAWN BY					
CHECKED BY					
SCALE					
PROJECT NO.					
DRAWING NO.					
PROJECT NAME					
DATE					
REV					

**URBAN EDGE**  
LANDSCAPE ARCHITECTS  
Level 2, 30 Market Street  
Sydney NSW 2000  
t: +61 (0)2 9550 1200  
e: info@urbanedgearchitects.com.au

**aston**  
www.aston.org.au

PEET - ASTON (N)VERGLEIN &  
SCENERY DRIVE - CHAMBERBURN  
STAGE 31 BUND PLANTING  
LANDSCAPE CONSTRUCTION DOCUMENTATION  
BUND DETAILS

MAY 2019  
13038  
L3

## ANNEXURE B - PRIORITY WEED SPECIES LIST

The purpose of this information is to provide an indicative list of problem weed species.

This list is not definitive and additional species may be required to be controlled depending on their impact.

State controlled and state prohibited weeds are not included however any contractor suspecting that these species are present must inform Melbourne Water and DPI to ensure appropriate control is undertaken.

PRIMARY CONTROL USUALLY FOR SITE PREPARATION		SECONDARY CONTROL USUALLY FOR MAINTENANCE	
<i>Agrostis capillaris s.l.</i>	Brown-top Bent	<i>Allium triquetrum</i>	Three-corner Garlic
<i>Anthoxanthum spp.</i>	Vernal Grass	<i>Arctotheca calendula</i>	Cape Weed
<i>Crocoshia X crocosmiflora</i>	Montbretia	<i>Aster spp.</i>	Aster
<i>Cynodon dactylon var. dactylon</i>	Couch	<i>Avena spp.</i>	Oat
<i>Cyperus eragrostis</i>	Drain Flat-sedge	<i>Brassica spp.</i>	Turnip
<i>Dactylis glomerata</i>	Cocksfoot	<i>Briza spp.</i>	Quaking Grass
DOCK	Any genus eg Acetosa, Rumex etc.	<i>Bromus spp.</i>	Bromus
<i>Echium plantagineum</i>	Paterson's Curse	<i>Chenopodium spp.</i>	Fat Hen
<i>Echinochloa spp.</i>	Barnyard Grass	<i>Conyza spp.</i>	Fleabane
<i>Ehrharta spp.</i>	Veldt Grass	<i>Echium spp.</i>	Bugloss
<i>Galenia pubescens var. pubescens</i>	Galenia	<i>Erodium spp.</i>	Eg Common Herons Bill
<i>Genista spp.</i>	Broom	<i>Fumaria spp.</i>	Fumitory
<i>Glyceria spp.</i>	Eg Reed Sweet Grass	<i>Galium aparine</i>	Cleavers
<i>Holcus spp.</i>	Fog Grass	<i>Lactuca spp.</i>	Lettuce
<i>Hordeum spp.</i>	Barley Grass	<i>Lolium spp.</i>	Rye Grass
<i>Juncus spp.</i>	Eg Jointed Rush	<i>Lotus spp.</i> (naturalised)	Trefoil

<i>Leersia oryzoides</i>	Rice Cut-grass	<i>Medicago spp.</i>	Medic
<i>Myriophyllum aquaticum</i>	Parrot's Feather	<i>Ornithopus spp.</i>	Bird's Foot
<i>Nassella spp.</i>	Eg Serrated Tussock, Chilean Nettle Grass etc	<i>Sisymbrium spp.</i>	Mustard
<i>Nasturtium spp.</i>	Watercress	<i>Solanum spp.</i>	Eg Black Nightshade
<i>Oxalis spp.</i> (naturalised)	Wood Sorrel	<i>Sonchus sp</i>	Eg Common Sow Thistle
<i>Paspalum spp.</i>	Eg Water Couch, Paspalum	Taraxacum species group 1	Garden Dandelion
<i>Pennisetum spp.</i>	Eg Kikuyu	THISTLES	Any genus eg. Cirsium, Helminthotheca, Cynara
<i>Phalaris spp.</i>	Canary Grass	<i>Trifolium spp.</i>	Clover
<i>Phytolacca octandra</i>	Red-ink Weed	NB Species have designated into PRIMARY and SECONDARY as an indication of when control efforts are most likely to be required however individual sites may respond differently depending on management and external factors. Species may be present in one or both phases and control will be required at the discretion of Melbourne Water.	
<i>Plantago spp.</i>	Eg Ribwort		
<i>Polygonum aviculare s.l.</i>	Prostrate Knotweed		
<i>Polypogon spp.</i>	Beard Grass		
<i>Ranunculus spp.</i>	Eg Creeping Buttercup		
<i>Romulea spp.</i>	Onion Grass		
<i>Rubus fruticosus spp. agg.</i>	Blackberry		
<i>Sagittaria spp.</i>	Sagittaria		
<i>Sparaxis spp.</i>	Harlequin Flower		
THISTLES	Any genus eg. Cirsium, Helminthotheca, Cynara		
<i>Typha spp.</i>	Eg Lesser Reed Mace		
<i>Vinca spp.</i>	Periwinkle		
<i>Watsonia spp.</i>	Watsonia		
<i>Xanthium spp.</i>	Eg Bathurst Burr		

## **Appendix 4 – Engineered Footing Zone Specifications**

Construction within the Engineered Footing Zone must utilise a foundation system that has been designed to be fully suspended with the piles founded within the underlying natural material.

# Appendix 5 – Permanent Reservoir Protection Plan

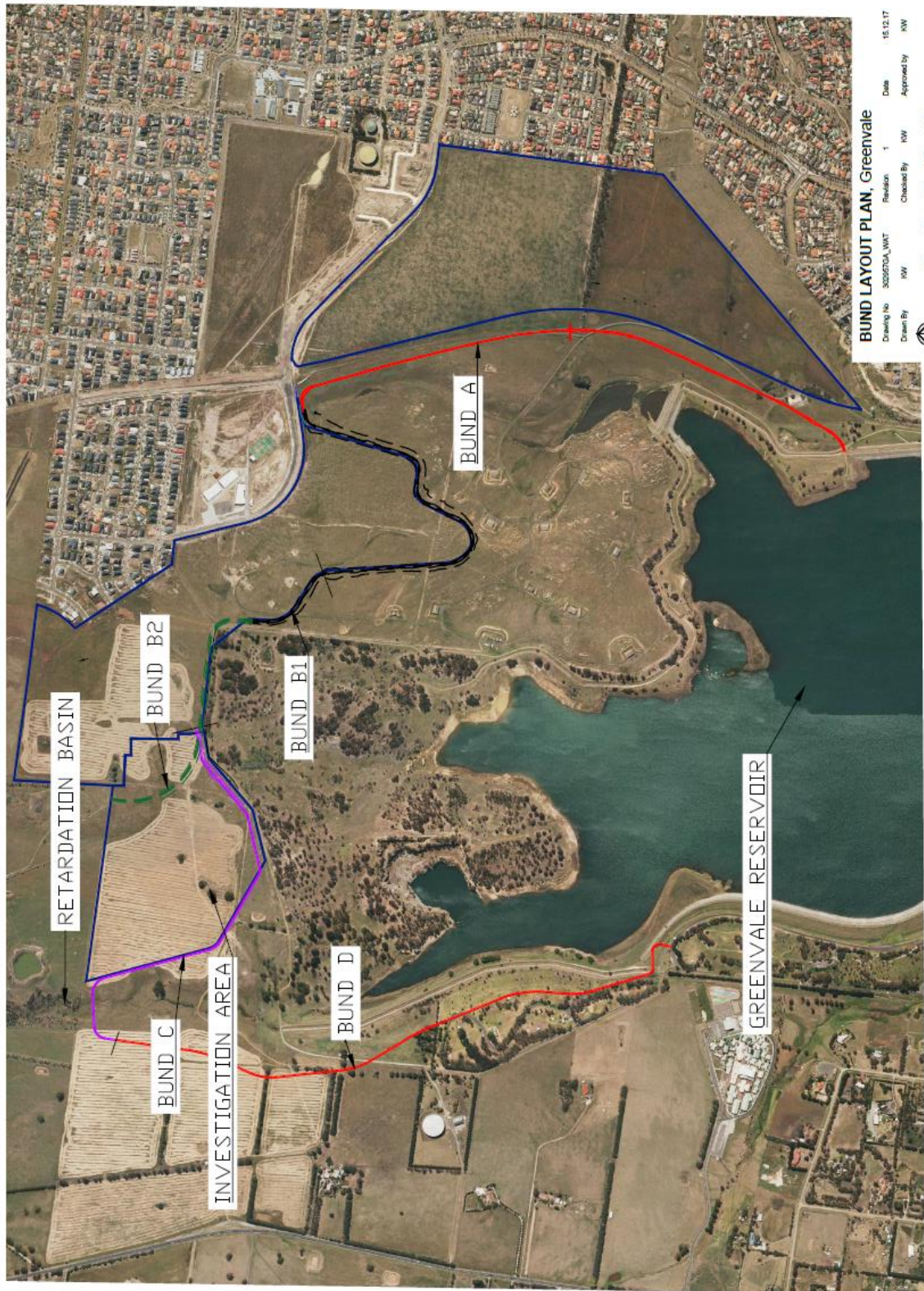

BUND LAYOUT PLAN  
 © 3005703A\_WWT